

**ULTRASONIC FLOWMETER
SONIX 30D**

INSTRUCTION FOR ASSEMBLY AND OPERATING

SONIX®
Industrial Electronic Devices
ul. Leopolda Lisa-Kuli 12, 05-270 Marki, Poland
phone:+4822-7811133, fax: +4822-7811644
www.sonix.com.pl

Contents

GENERAL INFORMATIONS ON SAFETY.....	3
Introduction.....	3
Symbols.....	3
Disclaimer.....	3
INTRODUCTION.....	4
Component parts	4
List of supplied elements.....	4
Purpose	4
Basic technical data	4
ASSEMBLY.....	5
Mechanical assembly of the flow sensor	5
Measurement example of sewage flow in a gravitational pipeline	5
Length of straight sections of the pipeline.....	5
Recommendations for the flow sensor assembly.....	6
The producer's supervision over the assembly and start-up	6
Space for the assembly of ultrasound probes	6
User's preparation for assembly	7
Assembly of the measuring transducer.....	7
Electrical connections	8
Probe's cable correct ending.....	8
OPERATING.....	9
General Information	9
Descriptions of the menu.....	10
Basic main screens.....	10
E0 Flow Volume.....	10
E1 Upper threshold Lower threshold.....	10
E2 Diagnostic screen.....	10
E3 Diagnostic messages.....	11
E4 Working time Time of correct work.....	11
E5 Serial number Program version Checksums.....	11
E6 SONIX phone number.....	11
E7 Access code.....	11
User functions screens.....	11
F1 Range flow Qp.....	11
F2 Setting the thresholds.....	12
F3 Change of the current output properties.....	12
F4 Parameters of the RS485 output.....	12
F5 Time constant.....	12
F6 Change of display precision	12
F7 Access code change	12
F8 Temporary volume.....	12
F9 Calibration of the current output	12
F10 Calibration of the pulse output	12
F11 Language selection.....	12
F12 Starting the backlight.....	12
F13 Pulse unit change.....	12
F14 Averaging.....	12
F15 Amplification.....	12
ERRORS.....	13
General information.....	13
Diagnostic messages.....	13
Servicing	13
THE SERIES RS485 OUTPUT.....	14
Protocol description.....	14
Electrical connections.....	14
List of registers.....	15
GUARANTEE CERTIFICATE	16

GENERAL INFORMATIONS ON SAFETY

- Introduction**
- Assembly and operating of the flowmeter is not allowed without reading, understanding and following the informations in this manual
 - Service of the flowmeter performs SONIX only
 - For power supply of the flowmeter use 1-phase mains with protective earth
 - Do not use the flowmeter with removed cover
 - Before removing cover switch off power supply
 - The recommendations and warnings contained in this manual and placed on the flowmeter should be followed

Symbols The symbols used in this manual or placed on the flowmeter have the following meaning:



Attention: Risk of electrical shock



PROTECTIVE EARTH TERMINAL



Attention: Identify conditions that could result in injury or loss of life and also could result in flowmeter damage. In each case the explanation is in this manual.

- Disclaimer**
- Using the flowmeter in a way or in conditions incompatible with this manual may result in flowmeter damage, loss of warranty or reducing protection provided by the flowmeter
 - SONIX reserves the right to change the product in order to increase its utility values or adjust it to current regulations. Such changes may not be taken into account in the current version of the manual. SONIX is not responsible for consequences it imply.
 - The purchaser is responsible for the selection of suitable flowmeter
 - Warranty is given in accordance with terms specified in Guarantee Certificate

INTRODUCTION

Component parts

The SONIX 30D flowmeter consists of a flow sensor with 2 or 6 ultrasonic probes and a measuring transducer connected together with probes cables. The flow sensor is available in three versions:

1. An U-shaped section ended with flanges or a screw thread (DN15...40)
2. A section ended with flanges (DN50...200)
3. An existing section of a pipeline (DN250...2000)

Additional equipment:

- Flow simulator SONIX S2
- Probes exchangeable under pressure for versions 3 (from DN250)

List of supplied elements

The following elements constitute the flowmeter set:

- a measuring transducer
- a flow sensor with two or six ultrasonic probes including cables
- instructions for Assembly and Operating and a Guarantee Certificate
- "wet" calibration certificate for the flowmeters calibrated in the SONIX company flow stand or theoretical calibration certificate

Purpose

Measurement of flow intensity and summing the volume of flowing liquids in closed, fully filled pipelines in both directions. Measured values are available on pulse and current outputs as well as on RS485 output with Modbus RTU protocol.

Influence of unsymmetrical flow velocity profile on measurement accuracy is significantly reduced thanks utilising 3 acoustic paths. In addition, dynamic paths replacement allow flowmeter to continue operation even if one or two paths fail.

The device is equipped with an LCD display. Operation is very simple thanks to intuitive menu. With 2 buttons, you can enable / disable each function.

Basic technical data

Pipe diameter range	15 ÷ 2000mm
Liquid flow velocity range	0 ÷ 15m/s
Liquid temperature range	0 ÷ 150 °C momentary to 180°C
Ambient temperature range	+5 ÷ +55 °C
Working pressure	0,03 ÷ 2,5 (4.0) MPa
Measurement accuracy	$\sigma = \pm 0.3\%$ m.v.
Measuring transducer protection category	IP54
Power supply overvoltage to Class II	wg IEC 60364-4-443
Rated pollution degree	2
Pulse output class	OC

ASSEMBLY

Mechanical assembly of the flow sensor

The choice of location and manner of the assembly of the flow sensor decides on the metrological properties of the device.

The following conditions must be met in order to provide correct measurement:

1. Lack of aeration of the liquid
2. 100% filling of the pipeline
3. Small attenuation of the ultrasound wave
3. Stabilized and symmetrical profile of liquid speed

The U-shaped sensor must be assembled horizontally or at the 45° angle max. The assembly position of the remaining type of sensor depends on the choice of the user. The probes must be located in the horizontal surface i.e. at both sides of the pipeline and not below and above it. The acceptable deviation from the level equals 25°.

Measurement example of sewage flow in a gravitational pipeline

The elements of the measuring system shown on the following figure provide the conditions necessary for the correct measurement:

- Deaeration of the inflowing sewage
- 100% filling of the pipeline
- Lack of accumulating deposit in the flow sensor
- Symmetrical profile of liquid speed

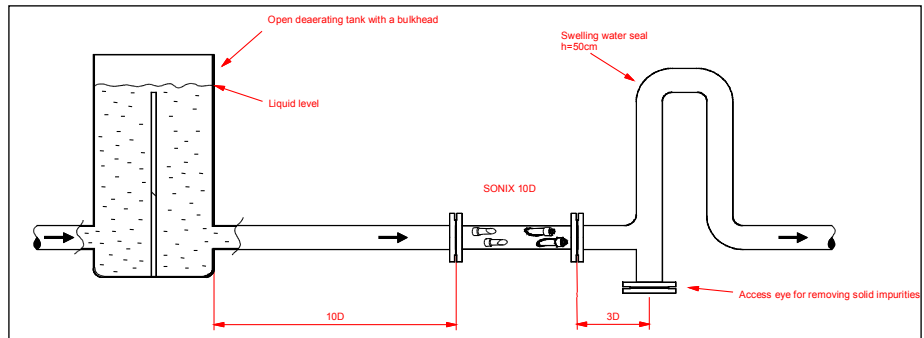

Length of straight sections of the pipeline

In the majority of cases, straight sections of the following lengths are sufficient:

- Inlet: 10D
- Outlet: 3D

Two- or more surface spatial configurations of the pipeline, the pump, not entirely closed valves, side inlets etc. require appropriate elongation of the straight sections before and behind the measuring spot. The U-shaped flow sensor does not require straight sections.

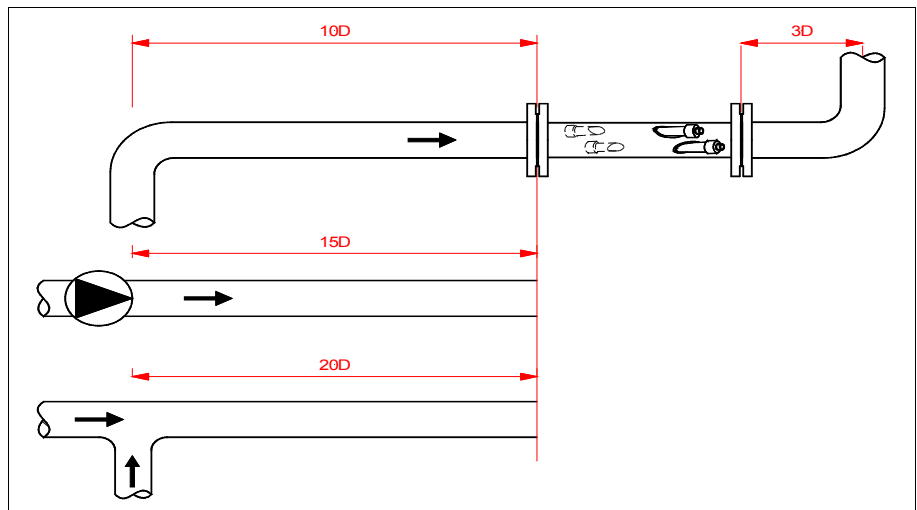

Recommendations for the flow sensor assembly



- Choose the longest available straight section of the pipeline. Install the sensor with probes on the 3/4 of its length starting from the inflow.
- Make sure that in the selected spot the liquid will not be aerated and air or solid impurities will not accumulate there.
- The inside diameter of the pipeline and the sensor should be the same.
- Install the sensor in such a way so the arrow on it is on top and shows the flow direction.
- The probes should be located horizontally on both sides of the pipeline (never vertically).
- Installations on vertical pipes is allowed but straight sections must be provided
- The seals of the flange connections cannot protrude into the inside of the pipeline (protruding seals can cause the increase of measurement error from ± 5 to even $\pm 40\%$)
- Do not hit the flow sensor with a hammer or other devices. It may damage the probes.
- The factory numbers of the measuring transducer and the sensor must be identical.
- Place the measuring transducer in a place appropriate for readings from the display and accessible for servicing team.
- Run the signal and supply cables in separate, own channels and attach them to the terminal strip of the flowmeter in accordance with the markings and colours.
- The length of the cable between the PE terminal of the flowmeter and the grounding vertical should not exceed a few meters.

The producer's supervision over the assembly and start-up (refers to assembly on an existing pipeline DN250...DN2000)

The following activities make up the assembly and the start-up of the flowmeter:

- Tracing points on the pipeline
- Making 6 holes of approx. 25mm diameter in the wall of the pipeline, drilling or acetylene cutting
- Electrical welding of attaching sleeves to the steel pipeline or screwing them to a cast iron one
- Assembly of ultrasound probes
- Assembly of the measuring transducer
- Connecting the measuring transducer to the ultrasound probes with transmission cables
- Start-up of the flowmeter
- Setting to zero in the case of stopped flow

Space for the assembly of ultrasound probes

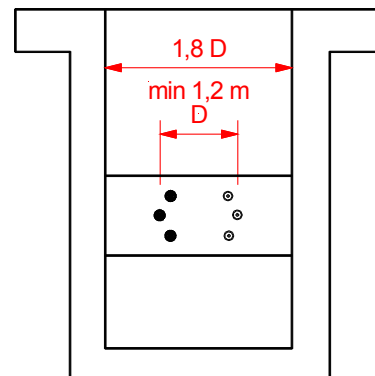
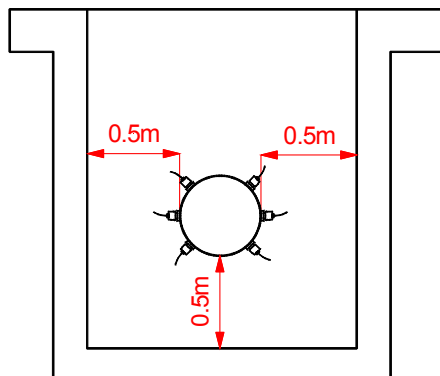

User's preparation for assembly



- Choice of the measuring spot on the pipeline and choice of measuring transducer location. The standard length of probes cables is 6 x 5m. In case of doubts, it is recommended to consult a SONIX representative.
- Preparation of the pipeline for assembly:
 - cleaning the surface of the pipeline from rust, insulation etc on the whole of its surface on the length of 1.8D
 - emptying the pipeline for welding and probe assembly. The tentative emptying time equals approx. 2 hours for a steel pipeline and approx. 6 hours for a cast iron one.
 - filling the pipeline in order to start-up the flow meter. After the filling, it is recommended to stop the flow for approx. 10 min in order to set the flowmeter to zero.
- Drilling or acetylene cutting of the holes of approx. 25mm diameters and electrical welding for a steel pipeline.
- Preparation of possible bushings, tubes, ducts etc. for probes cables: six cables of the approx. 6mm diameter.
- Arrangement of the 230V AC supply and signal cables connected to the measuring transducer.

Assembly of the measuring transducer

Protection category of the measuring transducer: IP54. It is acceptable to assembly the device in the open air in a heated protective cabinet. Due to temperature range of +5..+55 C during the summer months, the cabinet should be located in the shadow.

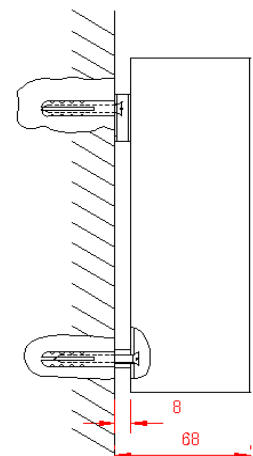
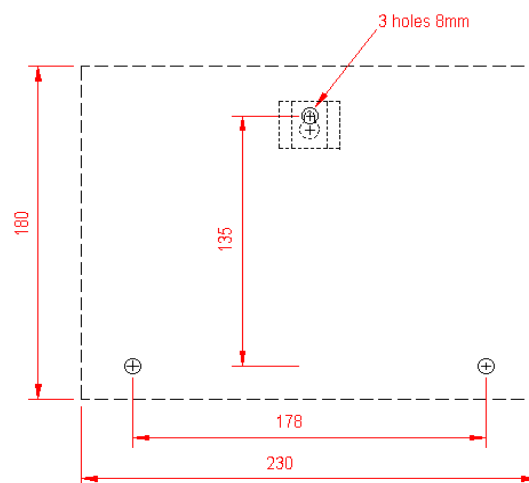

Power supply conection



- Protective earth conductor up to 2.5mm² (13 AWG) has to be connected to terminal (⊕) of the flowmeter
- Permanent connection to the mains 230V AC +10..-15% 50Hz 10VA
- It is advisable to provide an external overcurrent protection B type with a value of 1 A at a distance of no further than a few meters from the flowmeter with a properly labeled power switch
- The power supply should have applied a reliable limiters decreasing surge to a level which does not cause a danger
- Protective earth cable lenght should not exceed a few meters
- It is forbidden connecting to protective earth terminal any other cable than protective earth conductor
- Power supply cable should have a diameter 5..6mm and its cable gland should be assembled properly
- A fitter of the system is responsible for a security of the system comprising the flowmeter

Electrical connections

Remarks:

- cable shields of probes ABC connect to terminal 1
- cable shields of probes DEF connect to terminal 14
- additional OC output is programable from user menu level

Probe's cable correct ending

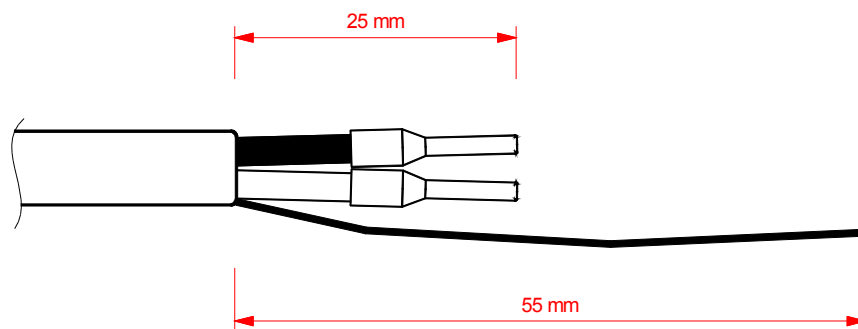

Flowmeter SONIX 30D

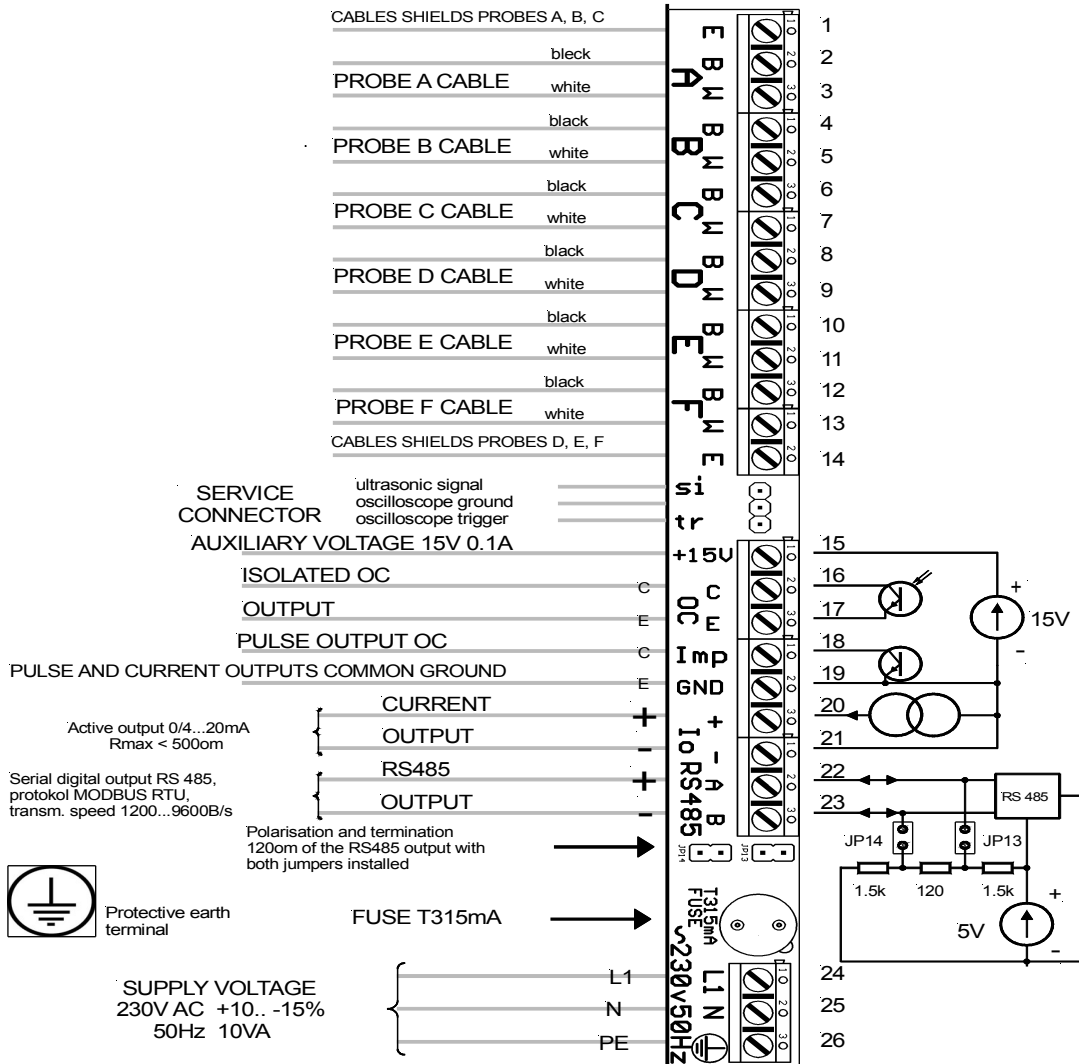

OPERATING

General Information

The user communicates with the device via the LCD 2x16 characters display using two push buttons for choice of functions or parameters. The principle of operating is as follows:

- The left one 'L': choice of function or digit
- The right one 'P': change of function or value
- Left and right one at the same time 'O': acceptance the change

The menu consists of 8 basic main screens and 15 screens of user's functions. User default access code: 1111

Descriptions of the menu

Basic main screens

Nr	Button	Upper line	Bottom line
E0		Current flow	Total volume
E1	Right	Upper threshold	Lower threshold
E2	Right	Diagnostic data	Diagnostic message
E3	Right	Diagnostic messages	Diagnostic messages
E4	Left	Working time	Time of correct work
E5	Left	Factory number L	Program version CRC
E6	Left	SONIX	SONIX phone number
E7	Both	Access code	****

E0 Flow Volume

The current flow in m³/h and the counted total volume in m³
For positive flow the volume counter counts up. For negative flow the counter can stop counting or can count down.
Power failure does not cause deletion of volume counter data or the loss of other data and parameters.
It is possible for the user to program the number (0..3) of displayed decimals.

E1 Upper threshold Lower threshold

Threshold programming is available in the user's functions.
On E1 screen are only displayed the programmed flow thresholds above and below. Only one threshold can be used at a time. It is available on OC output.

E2 Diagnostic screen

Upper line, from left:
-Flow speed in m/s
-Type and 2 digits value of amplification adjustment: r-manual adjusting, a-automatic adjusting
-Desired and current mode of work:
0 – lack of liquid
1 – works only on the AB path
2 – works only on the CD path
3 – works only on the EF path
4 – work only AB and CD paths
5 – work only CD and EF paths
6 – work only AB and EF paths
7 – 3 paths measurement
Diagnostic messages are displayed in the lower line:
'Measurement OK'
'Empty pipe' – empty pipeline or disconnected probes
'Low signal' – decreasing of the signal from pair of probes
'Out of l range' – flow exceeding the current range of flowmeter
'Out of v range' – too high liquid speed
'Disturbances' – more than 50% of interfered measurements
'Inconsistency' – mode of work or CRC inconsistency
'Adjustment' – ultrasonic signals are adjusting

E3 Diagnostic messages Current failure condition messages are displayed

E4 Working time Time of correct work Working time means the number of hours the supply of the meter was on. Time of correct work means the number of hours without signaling errors.

E5 Serial number Program version Checksums 7 or 8 digits factory number, L – checksum saved after verification
4 digits program version, CRC – current checksum

E6 SONIX phone number Logo of the SONIX company. Phone number of SONIX's service.

E7 Access code 4 digits access to user functions. Default value: 1111.

User functions screens

Using some of user's functions may interfere with the current flow measurements.
15-30s breaks may be observed.

Nr	Function
F1	Range flow Q_p
F2	Flow thresholds
F3	Current output
F4	RS485 output
F5	Time constant
F6	Display precision
F7	Access code change
F8	Momentary volume
F9	Current output calibration
F10	Pulse output calibration
F11	Language
F12	LCD backlight
F13	Pulse output unit
F14	Averaging
F15	Probes adjusting

F1 Range flow Q_p Programming of range flow in m^3/h

F2 Setting the thresholds	Programming of the lower and upper flow threshold in m ³ /h or t/h.
F3 Change of the current output properties	Change of output current: 0-20mA or 4-20mA Programming the characteristics of the current output: 1 – the output works symmetrically for the negative and positive flows 0 – the output work only for the positive flow bottom line: 1 – the current 4..0mA responds to flow 0..-0,25Q _p (only for 4..20mA range)
F4 Parameters of the RS485 output	Programming parity control: Odd, Even, None, address of the device: 01 _H ...FF _H and transmission speed: 1200B/s...9600B/s.
F5 Time constant	Changing 0...9 responds to app. 0,5...30s time constant. Time constant is separated from averaging mode (F14). This funkcion is unaccesible after verification.
F6 Change of display precision	Programming from 0 to 3 decimals for temporary flow and the totalized volume.
F7 Access code change	Allows user to change 4 digits access code to user funkcions. Default access code: 1111
F8 Temporary volume	The function allows dosing the liquid. The temporary liquid counter is set to zero and initiated with the left push button and stopped with the right one. The counter may also be operated by the RS485 series link (see Protocol of series transmission).
F9 Calibration of the current output	Forcing the 0, 4, 10, 15 or 20mA current in order to achieve a calibration of the device connected to the current output of the flowmeter.
F10 Calibration of the pulse output	Forcing the pulses in order to achieve a calibration of the device connected to the pulse output of the flowmeter. The number of pulses is in accordance with the programmed pulse unit (F13) and is shown as a percentage of the range flow Q _p . This funkcion is unaccesible after verification.
F11 Language selection	Menu language selection. Available are: Polish, English, Swedish
F12 Starting the backlight	Switching on/off the illumination of LCD display.
F13 Pulse unit change	Pulse output unit change in m ³ . Programmed unit must not be less than the unit displayed in bottom line. Pulse unit change is not available after verification.
F14 Averaging	Selection of the averaging method. Several methods are avaiable: - arithmetic mean - median - extended median - SONIX filter This funkcion is unaccesible after verification.
F15 Amplification	Six 3-digit numbers are visible on the screen. Each digit represents the amplification of the signal from the probe. The smaller the amplification the stronger signal from the probe. The correct values should be in range 100...500. When the amplification is greater then 750 it means that the signal is too small. This may be due to sediment on the probe's surface or damage of the probe.

ERRORS

General information

The last 2 digits displayed on the top line on the diagnostic screen E2 should be the same. It means that desired and current mode of work are the same. In the case of work on 3-paths this digits are 77. In the case the digits are not equal the failure is possible. For example digits 71 mean that the desired mode is working on 3 paths but flowmeter works on AB path only. In verified flowmeter checksums L and CRC shown on E5 screen should be the same. Furthermore checksum L is printed on meters label. When the checksums are not equal pulse output is blocked and the meter signals inconsistency.

Diagnostic messages

Na ekranach E2 i E3 wyświetlane są następujące komunikaty:

- „measurement OK” – flowmeter measures with no errors
- „adjustment” – amplification is being adjusted
- „disturbances AB, CD or EF” – more than 50% are disturbed
- „low signal AB, CD or EF” – a decrease of the signals from the pair of probes
- „inconsistency” – current and programmed mode of work are different or checksums are not equal for a verified flowmeter
- “measurement OK” - the measurements are done correctly.

Service



Service of the flowmeter is performed only by the SONIX servicing team. Service includes:

- supervision over the assembly and start-up of the flowmeter
- diagnostic and measurement error analysis of existing installations
- repair of flowmeter electronic
- replacement and adjustment of the ultrasonic probes
- „wet” calibration for flowmeters $DN \leq 300$
- theoretical calibration acc. to PN/M- 42370 for flowmeters $DN > 200$

THE SERIES RS485 OUTPUT

Protocol description

The MODBUS RTU protocol of series transmission is compliant with the current specification available at www.modbus.org Transmission speeds: 1200, 2400, 4800 or 9600 B/s. Addresses of the devices: 1 ...255.

Character format:

- 1 start bit
- 8 data bits
- 1 parity control bit (programmable: Odd, Even, None)
- 1 stop bit (or 2 stop bits when programmed to None).

Two functions are available:

03 or 04 – reading of the content of the flowmeter's register group

06 – recording data in the flowmeter register (register nr 31 only)

Examples of frames for the device of the 02_H address

1. Reading of 2 registers beginning from register no 10 of the following content:
register no 10: 057F_H register no 11: 9D1A_H
Order: 02,03,00,09,00,02,14,3A
Response: 02,03,04,05,7F,9D,1A,11,7C
2. Setting to zero and starting the temporary volume counter:
Order: 02,06,00,1E,00,01,28,3F
Response: 02,06,00,1E,00,01,28,3F
3. Stopping the temporary volume counter:
Order: 02,06,00,1E,00,00,E9,FF
Response: 02,06,00,1E,00,00,E9,FF

Electrical connections

The applied isolated interface is compliant with the EIA RS-485 standard. The transmission line must be connected in accordance with labels on the printed plate: R_A – higher potential, R_B – lower potential. In the case of severe electrical interferences or if the length of the cables exceed 300m, paired twisted 120Ω cable cat.4 wave resistance should be used.

If the flowmeter is located at the end of a transmission line exceeding 300m, line termination should be initiated by attaching the 2 jumpers (next to the fuse on the printed plate). Simultaneously with the termination, the line is also polarized with the approx 2.5V voltage. (see electrical connections of the flowmeter). The flowmeter is supplied with jumpers attached.

List of registers

Register no	Variable type		Name of the variable
1	float	LO	Flow m3/h
2		HI	
3	long int	HI	Positive volume m3
4		LO	
5	int		Positive volume l
6	float	LO	Liquid speed m/s
7		HI	
8	bit		errors 1... 16
9	long int	HI	Flowmeter serial number
10		LO	
11	long int	HI	Working time s
12		LO	
13	long int	HI	Time of correct work s
14		LO	
15	long int	HI	Temporary volume liter
16		LO	
17	float	LO	Temporary volume measurement time s
18		HI	
19	int		program vesion
20	float	LO	5 min average of the flow
21		HI	
22	float	LO	Hour average of the flow m3
23		HI	
24	int		CRCL
25			Reserved
26			Reserved
27	char		work mode: desired, current
28	int		CRC
29	int		AB probes adj., aut./manual

Remarks:

16 bit registers, char, int, long int – variable without a sign

CRCL – checksum saved afer verification

CRC – current checksum calculated every 60s

Register no 8 (errors), 1 in a given position means:

15 – correct measurement

14 – EF path signal adjustment

13 – CD path signal adjustment

12 – AB path signal adjustment

11 – low signal from EF pair of probes

10 – reserved

9 – low signal from the CD pair of probes

8 – outside the range of acceptable liquid speed

7 – checksum or mode of work inconsistency

6 – the flow exceeds the programmed current range value

5 – the same as bit 1

4 – reserved

3 – reserved

2 – flowmeter self test

1 – lack of liquid in the pipeline, damaged probe cables, damage of the analogue part of the flowmeter, liquid aeration, electrical interferences

0 – low signal from the AB pair of probes

SONIX® Industrial Electronic Devices
ul. Leopolda Lisa-Kuli 12
05-270 Marki, Poland
phone +4822-7811133
fax +4822-7811644
sonix@sonix.com.pl

GUARANTEE CERTIFICATE

1. The producer guarantees good quality of the product and its meeting the parameters defined in the Instruction for Assembly and Operating.
2. The guarantee period covers 36 months from the date of sales.
3. The free of charge guarantee repair shall be done within 48 hours from delivering the product to the producer's.
4. The producer undertakes to perform post-guarantee repairs within the dates specified in point 3.
5. The guarantee shall not remain valid in the case of:
 - mechanical damage to the product
 - interferences to the inside of the product except for the cases defined in the Instruction for Assembly and Operating
 - operation incompliant with the Instruction for Assembly and Operating
6. The guarantee does not cover complaints relating to incorrect working caused by external factors or by damage of the product (e.g. the probes' surface covering with deposit, presence of air in the pipeline, exceeding the allowed temperature limit for the ultrasound probes etc.).

Name of the product: ULTRASOUND FLOWMETER, type: SONIX 30D

Purchasing company:.....

Factory numbers:

The SONIX 30D Flowmeter.....

Date of sale:.....